

Features

- Wide 3.6V to 24V Input Voltage Rang
- 0.22V Constant Current Sense Voltage
- Directly drive 3~8 Series 1W LED
- Fixed 400KHz Switching Frequency
- Max. 2A Switching Current Capability
- Up to 92% efficiency
- Excellent line and load regulation
- EN PIN TTL shutdown capability
- Internal Optimize Power MOSFET
- Built in LED Open Protection
- Built in Soft-Start Function
- Built in Frequency Compensation
- Built in Thermal Shutdown Function
- Built in Current Limit Function
- Available in SOP8L package

Applications

- LED Lighting
- Boost constant current driver
- Monitor LED Backlighting
- 7' to 15' LCD Panels

General Description

The XL6001 regulator is fixed frequency PWM Boost (step-up) LED constant current driver, capable of driving Series 1W LED units with excellent line and load regulation. The regulator is simple to use because it includes internal frequency compensation and a fixed-frequency oscillator so that it requires a minimum number of external components to work.

The XL6001 could directly drive 5~8 Series 1W LED units at $V_{IN} > 12V$.

The PWM control circuit is able to adjust the duty ratio linearly from 0 to 90%. An enable function, an over current protection function is built inside. An internal compensation block is built in to minimize external component count.



Figure1. Package Type of XL6001

Pin Configurations

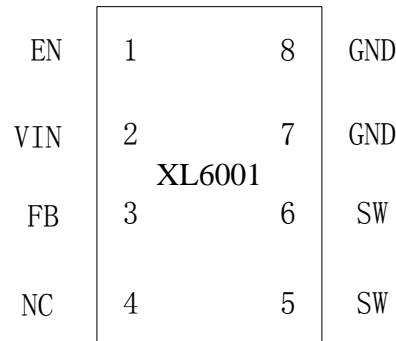

Figure2. Pin Configuration of XL6001 (Top View)

Table 1 Pin Description

Pin Number	Pin Name	Description
1	EN	Enable Pin. Drive EN pin low to turn off the device, drive it high to turn it on. Floating is default high.
2	VIN	Supply Voltage Input Pin. XL6001 operates from a 3.6V to 24V DC voltage. Bypass Vin to GND with a suitably large capacitor to eliminate noise on the input.
3	FB	Feedback Pin (FB). The feedback threshold voltage is 0.22V.
4	NC	No Connected.
5,6	SW	Power Switch Output Pin (SW). Output is the switch node that supplies power to the output.
7,8	GND	Ground Pin.

Function Block

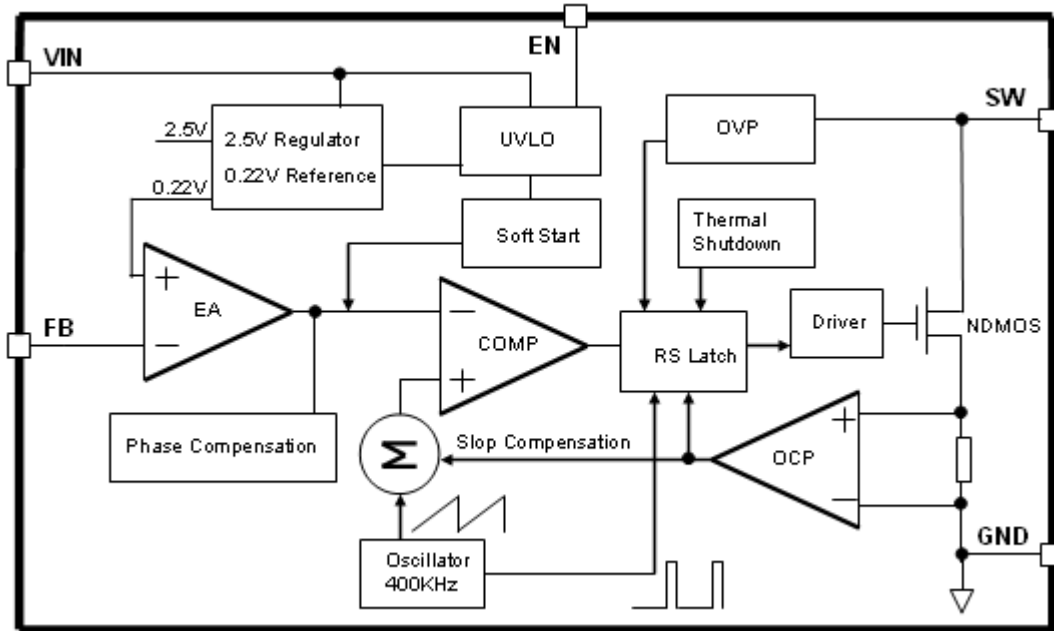

Figure3. Function Block Diagram of XL6001

Typical Application Circuit

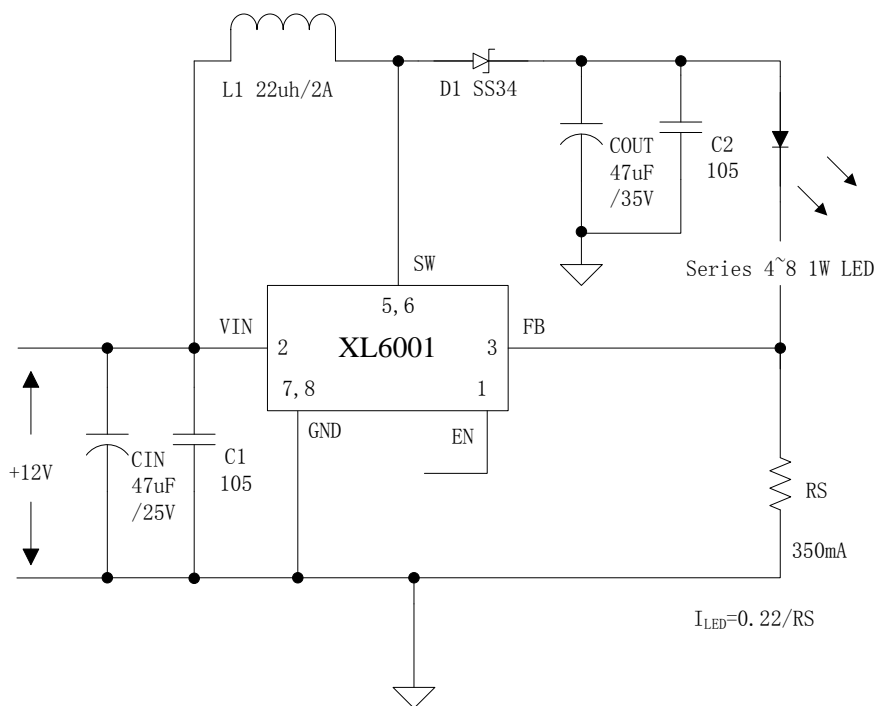

Figure4. XL6001 Typical Application Circuit

400KHz 32V 2A Switching Current Boost LED Constant Current Driver

XL6001

Ordering Information

Order Information	Marking ID	Package Type	Packing Type Supplied As
XL6001E1	XL6001E1	SOP8L	2500/4000 Units on Tape & Reel

XLSEMI Pb-free products, as designated with “E1” suffix in the par number, are RoHS compliant.

Absolute Maximum Ratings (Note1)

Parameter	Symbol	Value	Unit
Input Voltage	V_{in}	-0.3 to 26	V
Feedback Pin Voltage	V_{FB}	-0.3 to V_{in}	V
EN Pin Voltage	V_{EN}	-0.3 to V_{in}	V
Output Switch Pin Voltage	V_{Output}	-0.3 to 32	V
Power Dissipation	P_D	Internally limited	mW
Thermal Resistance (SOP8) (Junction to Ambient, No Heatsink, Free Air)	R_{JA}	100	°C/W
Operating Junction Temperature	T_J	-40 to 125	°C
Storage Temperature	T_{STG}	-65 to 150	°C
Lead Temperature (Soldering, 10 sec)	T_{LEAD}	260	°C
ESD (HBM)		>2000	V

Note1: Stresses greater than those listed under Maximum Ratings may cause permanent damage to the device. This is a stress rating only and functional operation of the device at these or any other conditions above those indicated in the operation is not implied. Exposure to absolute maximum rating conditions for extended periods may affect reliability.

400KHz 32V 2A Switching Current Boost LED Constant Current Driver

XL6001

XL6001 Electrical Characteristics

T_a = 25 °C; unless otherwise specified.

Symbol	Parameter	Test Condition	Min.	Typ.	Max.	Unit
<i>System parameters test circuit figure4</i>						
VFB	Feedback Voltage	V _{in} = 5V to 12V, V _{out} =24V I _{load} =100mA	209	220	231	mV
Efficiency	η	V _{in} =12V , V _{out} = 6*1W LED I _{out} =0.3A	-	92	-	%

Electrical Characteristics (DC Parameters)

V_{in} = 12V, GND=0V, V_{in} & GND parallel connect a 47uf/25V capacitor; I_{out}=50mA, T_a = 25 °C; the others floating unless otherwise specified.

Parameters	Symbol	Test Condition	Min.	Typ.	Max.	Unit
Input operation voltage	V _{in}		3.6		24	V
Shutdown Supply Current	I _{STBY}	V _{EN} =0V		70	100	uA
Quiescent Supply Current	I _q	V _{EN} =2V, V _{FB} =Vin		2.5	5	mA
Oscillator Frequency	F _{osc}		320	400	480	Khz
Switch Current Limit	I _L	V _{FB} =0		2		A
Output Power NMOS	R _{dson}	V _{in} =12V, I _{sw} =2A		110	120	mohm
EN Pin Threshold	V _{EN}	High (Regulator ON) Low (Regulator OFF)		1.4 0.8		V
EN Pin Input Leakage Current	I _H	V _{EN} =2V (ON)		3	10	uA
	I _L	V _{EN} =0V (OFF)		3	10	uA
Max. Duty Cycle	D _{MAX}	V _{FB} =0V		90		%

400KHz 32V 2A Switching Current Boost LED Constant Current Driver

XL6001

Typical System Application for VIN=5V to driver 2~3 x 1W LED units

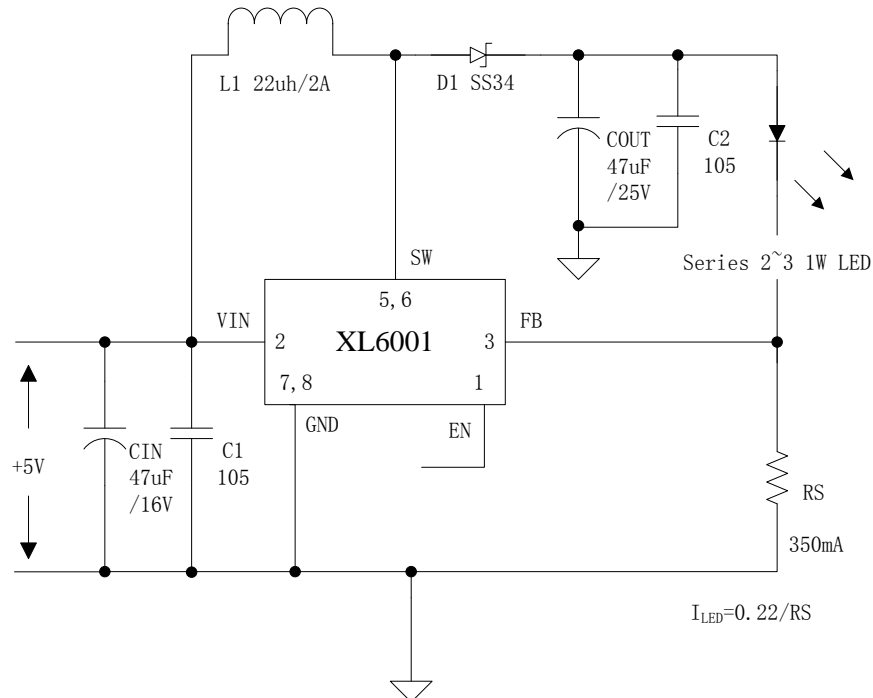

Figure5. XL6001 System Parameters Test Circuit (2~3 x 1W LED)

Typical System Application for VIN=12V to driver 4~8 x 1W series LED units

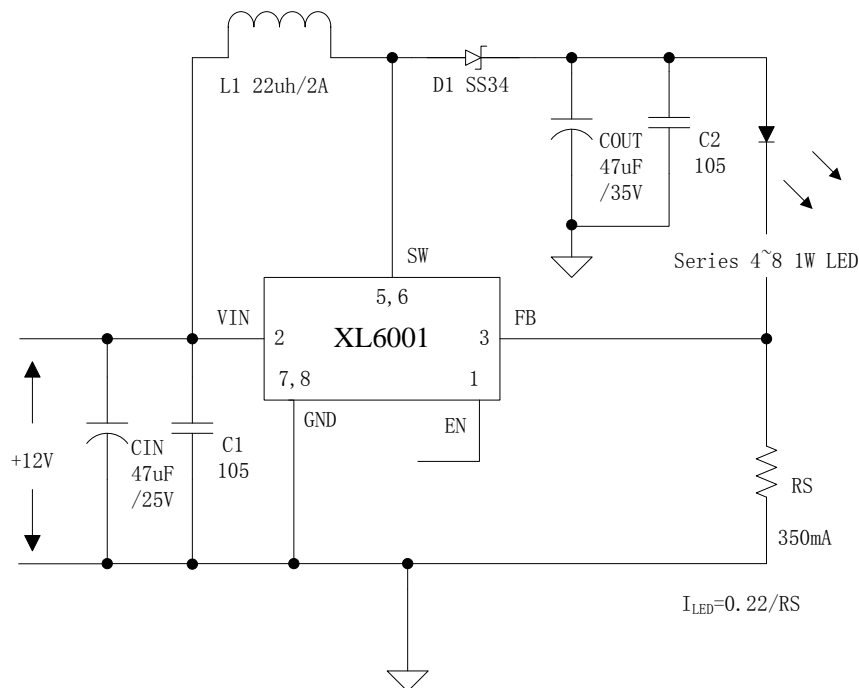

Figure6. XL6001 System Parameters Test Circuit (4~8 x 1W LED)

400KHz 32V 2A Switching Current Boost LED Constant Current Driver

XL6001

Typical System Application for VIN=12V to driver 4~8 x 1W series LED units With PWM Dimming

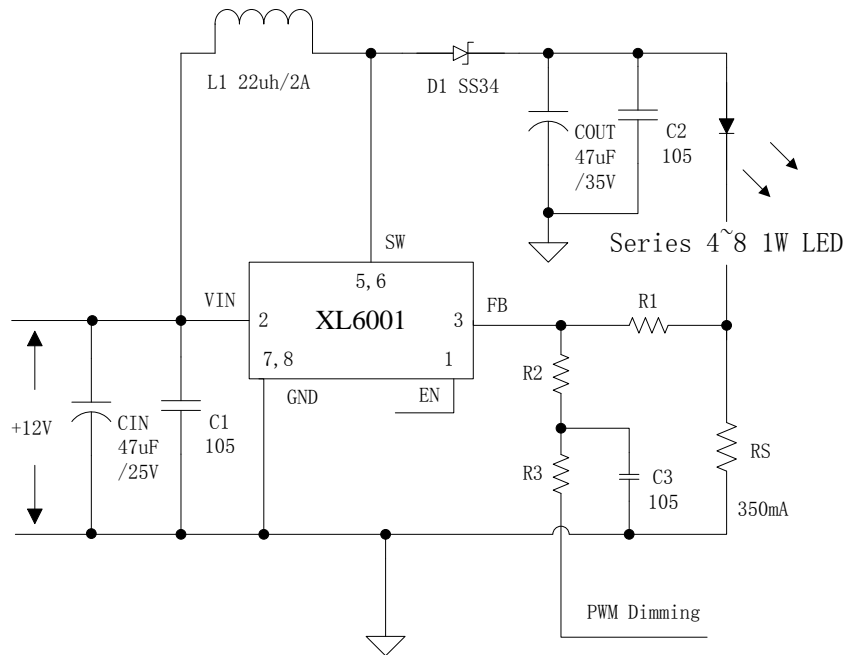

Figure7. XL6001 System Parameters Test Circuit (4~8 x 1W LED with PWM Dimming)

Typical System Application for SEPIC Buck-Boost LED Driver

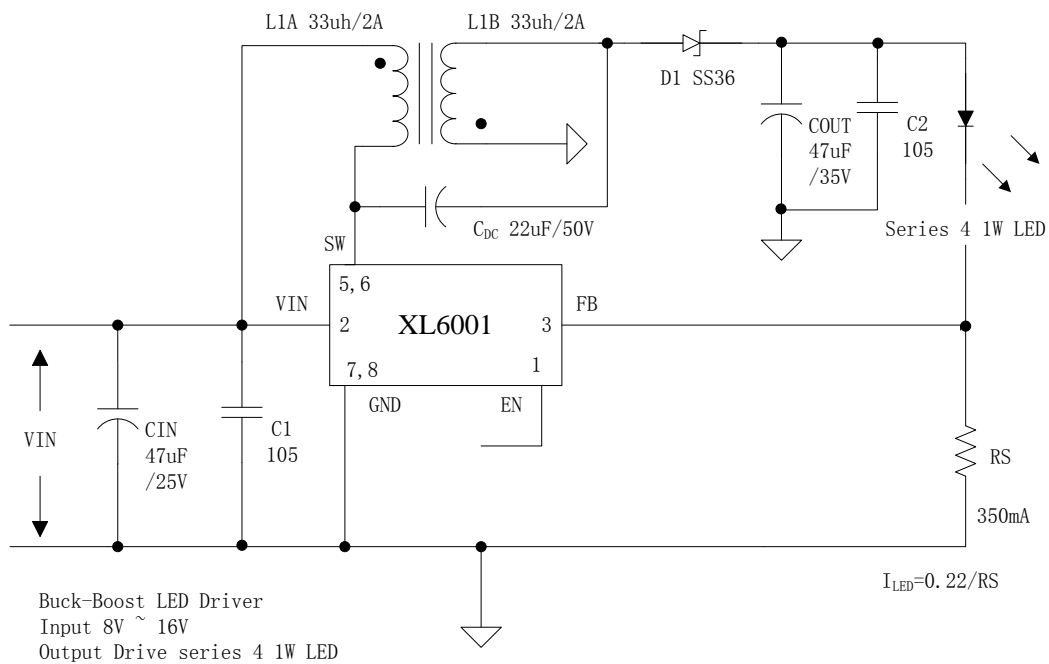
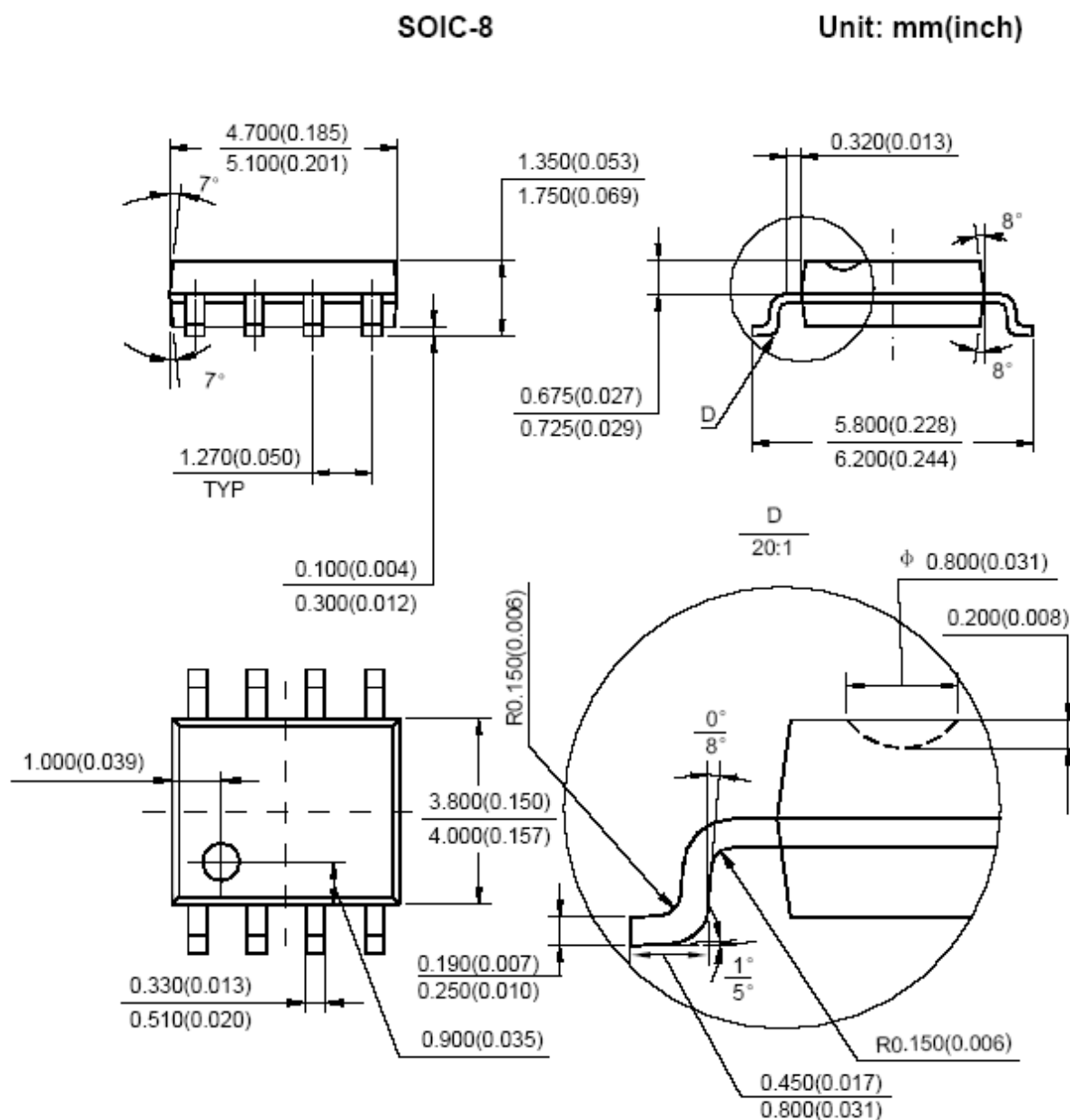

Figure8. XL6001 System Parameters Test Circuit (Buck-Boost LED Driver)

Package Information

SOP8 Package Mechanical Dimensions



Important Notice

XLSEMI reserve the right to make modifications, enhancements, improvements, corrections or other changes without notice at any time. XLSEMI does not assume any liability arising out of the application or use of any product described herein; neither does it convey any license under its patent rights, nor the rights of others. XLSEMI assumes no liability for applications assistance or the design of Buyers' products. Buyers are responsible for their products and applications using XLSEMI components. To minimize the risks associated with Buyers' products and applications, Buyers should provide adequate design and operating safeguards. XLSEMI warrants performance of its products to the specifications applicable at the time of sale, in accordance with the warranty in XLSEMI's terms and conditions of sale of semiconductor products. Testing and other quality control techniques are used to the extent XLSEMI deems necessary to support this warranty. Except where mandated by applicable law, testing of all parameters of each component is not necessarily performed. For the latest product information, go to www.xlsemi.com.