



800mA Single Chip Li-Ion and Li-Polymer Charger

General Description

The LP4065 is a complete constant-current/ constant voltage linear charger for single cell lithium-ion battery. Its SOT23-6 package and low external component count make the LP4065 ideally suited for portable applications. No external sense resistor is needed, and no blocking diode is required due to the internal MOSFET architecture. Thermal feedback regulates the charge current to limit the die temperature during high power operation or high ambient temperature. The charge voltage is fixed at 4.2V, and the charge current can be ISET programmed externally with a single resistor.

The LP4065 automatically terminates the charge cycle when the charge current drops to 1/10 setting current value after the final float voltage is reached.

When the input supply is removed, the LP4065 automatically enters a low current state, dropping the battery drain current to less than < 1µA.

Other features include charge current monitor, under voltage lockout, automatic recharge and a status pin .

Order Information

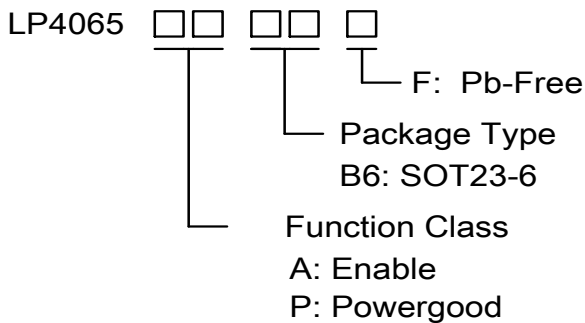

Features

- ◆ Input Voltage up to 28V
- ◆ Input Over Voltage Protection : 7V
- ◆ Short-circuit protection
- ◆ Programmable Charge Current :300mA to 800mA
- ◆ < 1µA Battery Reverse Current
- ◆ Protection of Reverse Connection of Battery
- ◆ No MOSFET, Sense Resistor or Blocking Diode Required
- ◆ Constant-Current/Constant-Voltage Operation with Thermal Regulation to Maximize Charge Rate Without Risk of Overheating
- ◆ SOT23-6 Package
- ◆ RoHS Compliant and 100% Lead (Pb)-Free

Applications

- ✧ Portable Media Players/Game
- ✧ Power Bank
- ✧ Bluetooth Applications
- ✧ PDA/MID

Marking Information

Device	Marking	Package	Shipping
LP4065AB6F	LPS BJYWX	SOT23-6	3K/REEL
LP4065PB6F	LPS BKYWX	SOT23-6	3K/REEL

Marking indication:
Y:Production year W:Production week X: Series Number



Functional Pin Description

Package Type	Pin Configurations	
	LP4065AB6F	LP4065PB6F
SOT23-6	<p>EN 1 6 ISET GND 2 5 BAT CHRГ 3 4 VIN</p>	<p>PG 1 6 ISET GND 2 5 BAT CHRГ 3 4 VIN</p>

Pin Description

No.	NAME		DESCRIPTION
	LP4065A	LP4065P	
1	EN		Charge Enable Input (active low).
		PG	Open-Drain Status Output. Low indicates the input voltage is above UVLO and the OUT (battery) voltage.
2	GND		GND is the connection to system ground.
3	CHRГ		Open-Drain Charge Status Output. When the battery is charging, the CHRГ pin is pulled low by an internal NMOS. When the charge cycle is completed, the pin could be pulled High by an external pull high resistor.
4	VIN		VIN is the input power source. Connect to a wall adapter.
5	BAT		BAT is the connection to the battery. Typically a 10μF Tantalum capacitor is needed for stability when there is no battery attached. When a battery is attached, only a 1uF ceramic capacitor is required.
6	ISET		Charge Current Program. The charge current is programmed by connecting a 1% resistor(R_{ISET}) to ground. $I_{BAT} = \frac{1500 \times V_{ISET}}{R_{ISET}}$



Typical Application Circuit

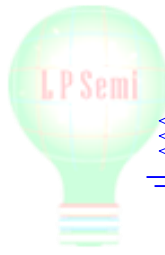
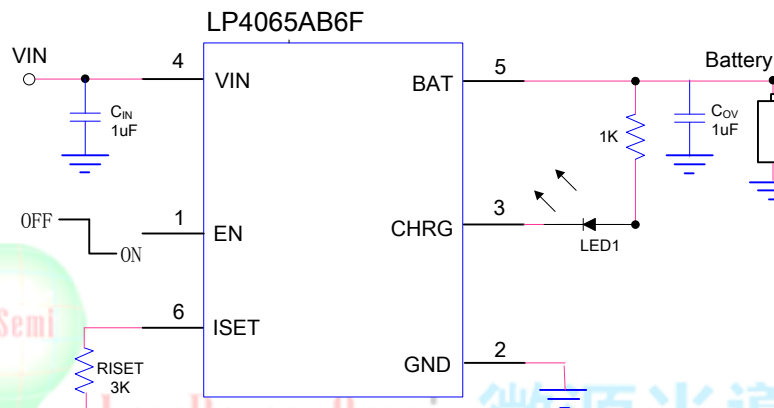
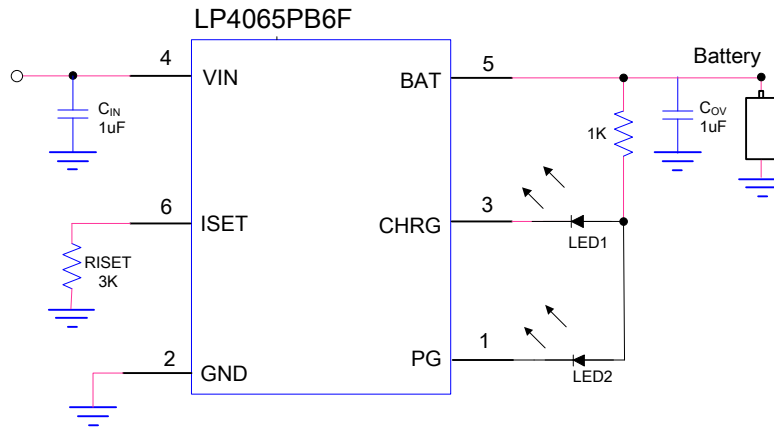

Function Block Diagram

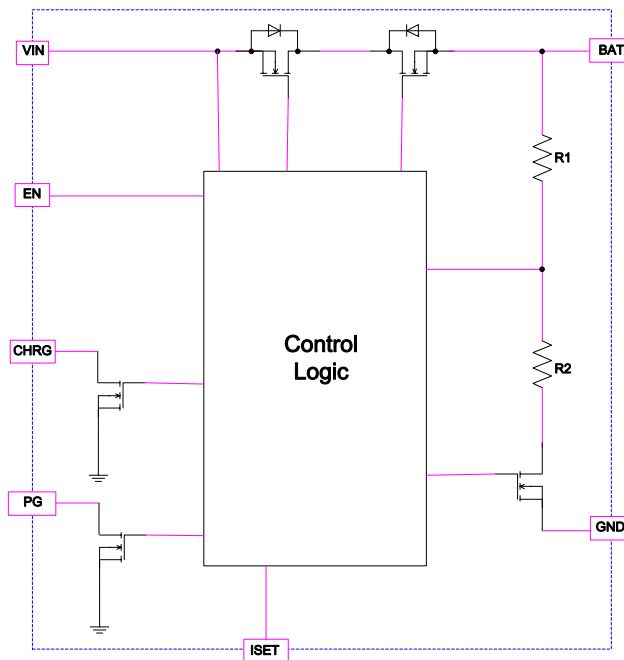



Absolute Maximum Ratings ^{Note 1}

- ✧ Input Voltage to GND ----- -0.3V to 28V
- ✧ BAT Voltage GND ----- - 5V to 7V
- ✧ Other pin to GND ----- -0.3V to 6.5V
- ✧ Maximum Junction Temperature ----- 125°C
- ✧ Maximum Soldering Temperature (at leads, 10 sec) ----- 260°C
- ✧ Operating Junction Temperature Range (T_J) ----- -20°C to 85°C
- ✧ Storage Temperature ----- -65°C to 165°C

Thermal Information

- ✧ Maximum Power Dissipation (P_D, T_A=25°C) ----- 0.6W
- ✧ Thermal Resistance (θ_{JA}) ----- 200°C/W

ESD Susceptibility

- ✧ HBM(Human Body Mode) ----- 2KV
- ✧ MM(Machine Mode) ----- 200V

Note 1. Stresses beyond those listed under “Absolute Maximum Ratings” may cause permanent damage to the device. These are stress ratings only, and functional operation of the device at these or any other conditions beyond those indicated in the operational sections of the specifications is not implied. Exposure to absolute maximum rating conditions for extended periods may affect device reliability.

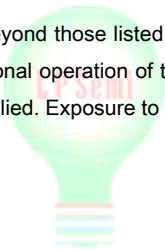



Electrical Characteristics

($T_A=25^{\circ}\text{C}$, $V_{IN}=5\text{V}$, unless otherwise noted.)

SYMBOL	PARAMETER	CONDITIONS	MIN	TYP.	MAX	UNITS
V_{IN}	Input Voltage		4.4	5	6.5	V
I_{IN}	Input Supply Current	$I_{BAT}=4.2\text{V}$		40		μA
V_{FLOAT}	Regulated Output (Float) Voltage	$I_{BAT}=40\text{mA}$,	4.158	4.2	4.242	V
V_{UV}	V_{IN} Under Voltage Lockout Threshold	From V_{IN} Low to High		3.3		V
V_{UV_HYS}	V_{IN} Under Voltage Lockout Hysteresis			150		mV
V_{OVP}	Input Voltage OVP	V_{IN} Rising		7		V
V_{OVP_HYS}	OVP Hysteresis			150		mV
I_{BAT}	BAT Pin Current	$R_{ISET}=3\text{k}$, Current Mode		500		mA
		$R_{ISET}=5\text{k}$, Current Mode		300		mA
		$V_{BAT}=4.2\text{V}$		1		μA
		$V_{IN}=\text{float or } 0\text{V}$		1		
I_{TRIKL}	Trickle Charge Current	$V_{BAT}<V_{TRIKL}$, $R_{ISET}=1\text{k}$, Current Mode		10		% I_{BAT}
V_{TRIKL}	Trickle Charge Threshold Voltage	V_{BAT} Rising		2.6		V
V_{TRHYS}	Trickle Charge Hysteresis Voltage			150		mV
I_{TERM}	Termination Current Threshold			10		% I_{BAT}
V_{ISET}	ISET Pin Voltage	$R_{ISET}=10\text{k}$, Current Mode		1		V
I_{CHRG}	CHRG Pin Weak Pull-Down Current	$V_{CHRG}=5\text{V}$			5	μA
V_{CHRG}	CHRG Pin Output Low Voltage	$I_{CHRG}=5\text{mA}$			0.5	V
I_{PG}	PG Pin Weak Pull-Down Current	$V_{OVP} < V_{IN} < V_{UV}$			5	μA
V_{PG}	PG Pin Output Low Voltage	$I_{PG}=5\text{mA}$			0.5	V
V_{EN_L}	EN Logic-Low Voltage Threshold				0.4	V
V_{EN_H}	EN Logic-High Voltage Threshold		1.4			V
ΔV_{RECHRG}	Recharge Battery Threshold Voltage	$V_{FLOAT}-V_{RECHRG}$		150		mV
T_{LIM}	Junction Temperature in Constant Temperature Mode			125		$^{\circ}\text{C}$



Application Information

Input Voltage Range

The LP4065 has built-in input voltage surge protection as high as +28V. The charger IC will be automatically disabled when the input voltage is lower than 3.3V or higher than 7.0V.

A charge cycle begins when the voltage at the VIN pin rises above the 4.4V level, when a battery is connected to the charger output. If the BAT pin is less than 2.6V, the charger enters trickle charge mode. In this mode, the LP4065 supplies approximately 1/10 the ISET programmed charge current to bring the battery voltage up to a safe level for full current charging. When the BAT pin voltage rises above 2.6V, the charger enters constant-current mode(CC), where the ISET programmed charge current is supplied to the battery. When the BAT pin approaches the final float voltage, the LP4065 enters constant-voltage mode(CV) and the charge current begins to decrease, and the battery full indication is set when the charge current in the CV mode is reduced to the programmed full battery current (1/10).

Charge Termination

A charge cycle is terminated when the charge current falls to 1/10th the ISET programmed value after the final float voltage is reached. This condition is detected by using an internal, filtered comparator to monitor the ISET pin. When the ISET pin voltage falls below 100mV for longer than tTERM (typically 1ms), charging is terminated.

ISET programming Charge Current

The charge current (IBAT) is set by a resistor (RISET) connecting from the ISET pin to GND. The relationship of the charge current and the programming resistance is established by the following equations (VISET=1V).

$$I_{BAT} = \frac{1500 \times V_{ISET}}{R_{ISET}}$$

Automatic Recharge

Once the charge cycle is terminated, the LP4065 continuously monitors the voltage on the BAT pin. A charge cycle restarts when the battery voltage falls below 4.05V (which corresponds to approximately 80% to 90% battery capacity). This ensures that the battery is kept at or near a fully charged condition and eliminates the need for periodic charge cycle initiations.

Enable Function

The LP4065 features an enable/disable function. An input "Low" signal at EN pin or if this pin is floating will enable the IC. To assure the charger will switch on, the EN turn on control level must below 0.4 volts. The charger IC will go into the shutdown mode when the voltage on the EN pin is greater than 1.4 volts. If the enable function is not needed in a specific application, it may be tied to GND or floating to keep the charge IC in a continuously on state.

Charge Status Indicator(CHRG&PG)

After application of a 5V source, the input voltage rises above the UVLO and sleep thresholds (VIN>VBAT+VDT),but is less than OVP (VIN<VOVP), then the PG turns on and provides a low impedance path to ground.

CHRG has two different states: strong pull-down (~5mA) and high impedance. The strong pull-down state indicates that the LP4065A is in a charge cycle. When the charger is entered CV mode and Once the charge current has reduced to the battery full charge current threshold (IBF), the CHRG pin will become high impedance.

Function	CHRG
Charging	High
Charge Finish	Low

Function	PG
VIN<UVLO	High
UVLO<VIN<OVP	Low
OVP<VIN	High



Thermal Limiting

An internal thermal feedback loop reduces the I_{SET} programmed charge current if the die temperature attempts to rise above a preset value of approximately 125°C. This feature protects the LP4065 from excessive temperature and allows the user to push the limits of the power handling capability of a given circuit board without risk of damaging the LP4065. The charge current can be set according to typical (not worst-case) ambient temperature with the assurance that the charger will automatically reduce the current in worst-case conditions.





Packaging Information

SOT23-6

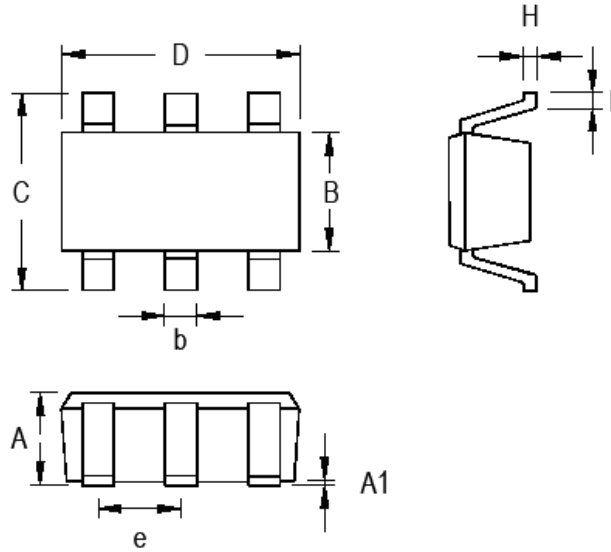

Symbol	Dimensions In Millimeters		Dimensions In Inches	
	Min	Max	Min	Max
A	0.889	1.295	0.031	0.051
A1	0.000	0.152	0.000	0.006
B	1.397	1.803	0.055	0.071
b	0.250	0.560	0.010	0.022
C	2.591	2.997	0.102	0.118
D	2.692	3.099	0.106	0.122
e	0.838	1.041	0.033	0.041
H	0.080	0.254	0.003	0.010
L	0.300	0.610	0.012	0.024